

# VENTILATION SOLUTIONS FOR SOCIAL HOUSING

HELPING CREATE HEALTHY, ENERGY EFFICIENT HOMES



RESIDENTIAL FANS



HEAT RECOVERY



COMMERCIAL FANS



DUCTING ACCESSORIES



## MORE THAN 60 YEARS' OF EXPERIENCE

Founded in 1955, Airflow has grown from one man's expertise in fan design and air flow measurement into a thriving international group. Renowned for its innovative approach to new product development and air movement techniques, Airflow can offer you a variety of ventilation solutions to suit your needs.

With our headquarters in High Wycombe, Airflow has subsidiaries in Germany and the Czech Republic and has global distributors from Norway to New Zealand.

Listening to the requirements of our customer enables Airflow's knowledgeable and committed staff to continually develop new and innovative products that raise standards and provide long term, reliable ventilation solutions.



### UNITED KINGDOM

High Wycombe (Head Office)

Our founder started the business in 1955, just one mile from the current site, which has been Airflow's headquarters since 1960, co-ordinating our global activities.



### GERMANY

Airflow has been serving ventilation products and air measurement devices to the German and European markets for over 50 years. Operating near Cologne, Airflow Germany has their own customer service, sales and technical sales teams.



### CZECH REPUBLIC

Founded in Prague over 20 years ago, the Airflow Czech Republic team offer sales and servicing of ventilation products for the Eastern European market.



## BETTER VENTILATED HOMES MAKE BETTER LIVES

The requirement for many more affordable homes continues as does the need to improve the quality of the existing housing stock. The Decent Homes Programme has taken great strides in upgrading older dwellings but there is still much to be done.

As we build new and regenerate older dwellings to a higher standard of insulation, so we increase the conditions for dampness and mould growth and an environment with poor indoor air quality to thrive.

Where the UK Government support any retrofit works, it requires these to be done to Publicly Available Specification (PAS) standard. Such standards that exist are PAS 2030:2017, and the new PAS 2035 due out in mid-2019. These are available from BSI. The aim is that by ensuring these standards are followed and adhered to the quality of work improves.



A key element of PAS2035 is the requirement to install effective ventilation in all properties, especially those where insulation measures are introduced.

Furthermore there is a requirement to check the ventilation in all properties and to upgrade the system when it fails to meet the specified criteria.

Therefore producing effective, efficient and compliant ventilation will be an obligation for social housing providers to combat the potentially harmful effects of dampness and mould and reduce the airborne pollutants which can result in a 'Toxic Home'.

## UNDERSTANDING THE ISSUES

A highly respected report concluded that 40,000 deaths a year can be linked to air pollution.

Toxic Home Syndrome can develop Allergies, Alzheimer's and strokes.

The health problems resulting from exposure to air pollution have a high cost to people who suffer from illness and premature death, to our health services and to business.

Source: *The Royal College of Physicians: Every Breath We Take: the lifelong impact of air pollution April 2016*



## WHAT IS 'TOXIC HOME'?

If you live in an air tight home with poor air quality, you and your family can experience headaches, long lasting colds and bronchitis as well as chronic asthma and allergies.

15.3 million homes in the UK are at risk of Toxic Home Syndrome from the build-up of moisture and airborne pollutants, Volatile Organic Compounds (VOC's) within the air in your home.

Poor indoor air quality can lead to dampness and mould developing and damaging the fabric of the home and the air we breathe.





## LANDLORDS LEGAL RESPONSIBILITIES

Creating a healthy, well ventilated environment is not just common sense, it is part of a landlords "Duty of Care" to their tenants well being.

The Housing Act and The Home Standard are just two examples of legislation on the statute books with embodied elements requiring systematic assessments of the condition of residential premises to ensure a dwelling is fit for human habitation.

Under the Defective Premises Act 1972, landlords are responsible for ensuring the habitability of rented accommodation. The landlord must perform any maintenance work that is deemed necessary for keeping the dwelling habitable for the tenant.

The Landlord and Tenant Act of 1985 does state that "the house shall be regarded as unfit for human habitation" if, and only if, it is so far defective in one or more of the following:

In that list VENTILATION appears as does FREEDOM FROM DAMP amongst other items that would deem the property unfit.

The above act has now had a further amendment by way of the Homes (Fitness for Human Habitation) Act 2018, this comes into force on the 20th March 2019.

The Bill will help private and social renter's, by giving them the right to take their landlord to court over unfit and unsafe conditions like the above in their home.

## HEALTHY HOMES

Health is defined by the World Health Organisation as "a state of complete physical, mental and social well-being".

The importance of building and crucially, maintaining homes to provide a safe, comfortable living environment and to protect the fabric of the dwelling is paramount.

## ENSURE THE CORRECT STANDARDS ARE FOLLOWED

When choosing a contractor it is important that they carry out any works to the correct standards. In lots of instances when Energy Efficiency Measures (EEM) are installed and the contractor does not work to the PAS standards then the EEM may not be effective or they may cause other problems within the dwelling. Choosing a contractor who is familiar with the Standards PAS 2030 2017 and PAS 2035, will go some way to ensure that you will not have condensation or moisture issues caused by poor or incorrect ventilation.

## TAKING CARE OF VENTILATION IN SOCIAL HOUSING SINCE 1969

Designed to meet the growing demand for a quality ventilation solution, particularly for the council housing build programmes of the 1970's, the LOOVENT was created.

Quiet, reliable and effective it has become the by word for social housing ventilation. With more than two million installed it is effective today in protecting your assets and clearing the air for tenants and owners, as it ever was. The current LOOVENT has a smaller energy consumption and is quieter, whilst still giving a class leading performance.

**MORE THAN TWO MILLION SOLD**



## SOLUTIONS AVAILABLE TO MEET THE BUILDING REGULATIONS



**Intermittent extractor fans – designed more with budget in mind than performance**



**Intermittent extractor fans – designed with performance and style in mind as well as reducing heat loss and backdraught**



**Intermittent extractor fans – designed to perform and be Quiet using a small amount of energy, the quietest fan available that performs (beware of silent imitations)**



**Constant trickle fans – Choices available for through the wall or challenging duct runs**



**Heat recovery ventilation – solutions from single room units to whole house units, even utilising the space above the hob rather than a cupboard**



**Retro - ducting means you can have central extraction without the need to conceal the ducting**



**If the dwelling does not have space for a central unit then Airflow manufacturers a unit that can go above your hob and also carry out the function of a cooker hood**



## PRACTISING WHAT WE PREACH

State-of-the-art training, showroom and conference centre.

This 500m<sup>2</sup> facility is designed to educate, inform and inspire all that come to this modern venue.

Within the Air Academy you will be guided through the history of ventilation and be able to see the first inclined manometer to go into commercial production as well as the first internet controllable domestic and commercial MVHR units in the UK.

Our fully operational displays will demonstrate the latest in air movement technology.

To book your FREE visit email us at:  
[marketing@airflow.com](mailto:marketing@airflow.com)



## TRAINING SERVICES

Airflow offers CPD sessions for architects, specifiers, M&E consultants and any organisation that wants to learn about ventilation, at a location of your choosing. Simply contact us to organise one of our Specification Managers to present these highly popular sessions at a date, time and location convenient for you.

Alternatively visit the Air Academy, where we run regular courses, see the website for dates and availability.

## RIBA APPROVED CPD



Understanding UK Building Regulations relating to Residential Mechanical Ventilation and Heat Recovery.

## CIBSE APPROVED CPD



Understanding Mechanical Ventilation with Heat Recovery for Commercial Applications.

## NICEIC TRAINING SCHEME

Airflow regularly hosts the two day NICEIC Competent Persons Ventilation Installer Scheme at the Air Academy. The only audited competent person's scheme for ventilation installers. The Air Academy is NICEIC Centre Number 296.



## DRIVEN BY TECHNOLOGY



- Mechanical Ventilation with Heat Recovery (MVHR)
- 'Smart' Environmental Controls - Temperature, Humidity, Energy
- Indoor Air Quality
- Air Source Heat pump
- VAV Zonal Control
- DX Coil Heating and Cooling
- Solar Panels
- Eco Lighting
- Exceptional air tightness
- Photovoltaics

## ENGAGEMENT

Airflow takes an active role in all things ventilation. Below are the organisations that we engage with to ensure we are always up to date with regulatory requirements. We also actively contribute to these organisations so as to drive standards

and improvements in all the sectors we operate in. Airflow is committed to ensuring its products perform to the requirements of industry.



Member: British Electrotechnical and Allied Manufacturers Association, committed to promoting best practise across the residential ventilation sector, associated with regulation, governance and installation.



Member: Residential Ventilation Association is dedicated to improving Ventilation products and standards in domestic dwellings.



Member: European Ventilation Industry Association is dedicated to raising standards of product design, energy performance, indoor air quality and sustainability.



Member: Fan Manufacturers Association consists of industry acknowledged fan manufacturing experts, who are heavily involved with government & European bodies.



Affiliate: Building Engineering Services Association takes an active interest in the building services and wider construction industries, voicing the views of members and driving for initiatives that represent the best interests of those who work within the built environment.



Member: Heating Ventilation Air Conditioning trade association, it is the largest member of the Federation of Environmental Trade Associations (FETA), HEVAC seeks to be a pro-active association collaborating with similar industry groups and government departments to strengthen sustainability as an essential component of resource efficiency.



Standards: There are mandatory requirements for all government backed schemes for EEM to meet PAS standards. Airflow contributed to the new PAS 2035 standard, by way of the Each Home Counts Review set up by the UK Government, that will be available by mid 2019 and will give clear guidance on what is required with

regards to ventilation in addition the PAS 2030:2017.



Participation in the 2018 all party parliamentary white paper calling on UK Government to focus on public health issues arising from poor indoor air quality. The objective is to drive up standards in home building to create a healthier indoor environment. The White Paper contains a number of recommendations so as to improve the indoor environment of the home.



Airflow participated to design, develop and introduce a Competent Persons Ventilation installer training scheme. Participants who pass the course have the opportunity to join the Competent Persons Installer register, annually audited and backed by a £25,000 insurance bond.



Using a trustmark registered business the consumer knows they are engaging an organisation that is thoroughly vetted, has a commitment to good customer service, technical competence and trading practices.



Sponsor: Good Homes Alliance, Vanguard Campaign is focussed on raising the awareness of improved ventilation in Local Authority and Housing Association new build and retrofit programmes.



Member: Passivhaus Trust provides leadership in the UK for the adoption of the Passivhaus standard and construction methodology which specifies Mechanical Ventilation with Heat Recovery. Airflow offers the largest range of Passive Haus Accredited MVHR units from stock.



Member: Kitchen Bathroom Bedroom Specialists Association is made up of independent, local kitchen, bedroom, bathroom and home office retailers promoting best practice design including ventilation.

## ISO 9001 2015 QUALITY MATTERS!



Airflow Developments Limited was the 152nd company to achieve the ISO 9001 (BS 5750) standard for Quality Management Systems. Today in the U.K there are now tens of thousands of certified organisations.

The ISO 9001 kite-mark is positive proof for our customers that their purchase will be tried and tested and provide years of trouble free operation.

## ISO 14001 2015 ENVIRONMENTAL MATTERS!



Airflow continues to lead the way in ensuring we do our utmost to reduce our environmental impact. We have achieved the stringent ISO 14001 Environmental Management Systems Standard.

If your supplier does not share these ideals, ask yourself why? Choose Airflow for a sustainable future.

# ARE YOUR INSTALLERS COMPETENT?

It does not matter if the correct product has been chosen for a project and its design and application is correct, if it is not installed correctly. Protect the fabric of your asset and the health and wellbeing of your tenants by ensuring you use a competent and trained installer for all your ventilation needs.

Your reputation as a provider of habitable housing depends on reliable, trained contractors delivering a quality build and high levels of repair, maintenance and improvements.

So why would you not pay the same attention to the standard of your ventilation products and installation? From an extract fan to a whole house system, ensuring a correct installation is key to creating a healthy indoor environment.



Checkout our upcoming courses visit: [www.airflow.com/training](http://www.airflow.com/training)

## WHO IS A COMPETENT PERSON?

Competent Person Schemes (CPS) allow registered installers who are competent in their field, to self-certify certain types of building work as compliant with the requirements of the Building Regulations in England and Wales.

Competent Person Schemes help to tackle the problem of unqualified builders by raising standards in the industry and enabling consumers to identify competent installers



## PLATINUM PROMISE

All customers of NICEIC registered contractors who have passed the course and then joined the NICEIC competent persons scheme will be covered by the NICEIC Platinum Promise. The Platinum Promise provides assurance to your customers that any work that has not been carried out in compliance with the building regulations will be rectified.

The Platinum Promise lasts for six years from the date of work completion and covers up to a limit of £25,000 for any one installation. It provides consumers with extra peace of mind and gives NICEIC registered contractors a competitive edge over others.

Residential ventilation, from a toilet extract fan to a mechanical ventilation with heat recovery system, is 'notifiable work' under the latest Building Regulations, every new installation or refurbishment requiring a new electrical circuit should be inspected, commissioned, tested and signed off by a suitably qualified person.

Airflow operate the NICEIC approved Domestic Ventilation Systems installer training course which enables participants to demonstrate a high level of competency mapped against relevant National Occupational Standards and the latest Building Regulations affecting residential ventilation.

This two day course comprises both practical "hands-on" system training and a written assessment following an introduction to relevant Building Regulations and supporting documents.

- Comprehensive two day ventilation installer training to the latest Building Regulations
- Learn about 'Best Practices' ventilation installation techniques
- Benefits from a Nationally Recognised Qualification
- Add credibility and opportunity to your business
- Understand the use of the correct test equipment
- Successful candidates eligible to join the Competent Persons Ventilation Installer Scheme.



# MEETING THE STANDARD

The 2013 building Regulations, Approved Document F1, means of ventilation prescribes minimum rates of ventilation within a dwelling. Compulsory for any project requiring planning consent and sign off by building control it is of course good practise to follow regulations for any repair, maintenance and improvement work which impacts on the indoor environment.



## Does your installer know about the compliance guide

Accompanying Approved Document F1 is the Domestic Ventilation Compliance Guide 2010. This guide provides help to comply with the Building Regulations 'Best Practise' advice for installing, testing and commissioning fixed ventilation systems in new and existing dwellings.



## PRIMARY MECHANICAL SYSTEMS IN APPROVED DOCUMENT F1

### SYSTEM 1 - Background Ventilators and Intermittent Fans

Room	Intermittent Extract Fan
Kitchen	30 l/s (adjacent to hob) or 60 l/s (elsewhere)
Utility Room	30 l/sec
Bathroom	15 l/sec
Toilet	6 l/sec

- Mechanical Intermittent Extract Fans located in the wet rooms to extract pollutants quickly at a high rate.
- Can be controlled either:
  - Manually via integral / remote switch
  - Automatically, typically via humidity, CO<sub>2</sub>, motion or other sensors.
- Normally wall or ceiling mounted and ducted direct to outside air using the most economical route.
- Replacement air enters the building via background ventilators, typically in the form of window vents located in the head of window frames.

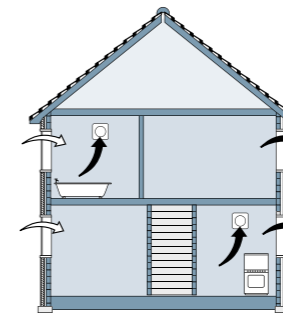

### SYSTEM 3 - Centralised continuous Mechanical Ventilation

Room	Continuous Extract Fan
Kitchen	13 l/sec
Utility Room	8 l/sec
Bathroom	8 l/sec
Toilet	6 l/sec

- Background vents in dry rooms only.
- Extracts continuously at a low rate and incorporates a boost facility to extract pollutants at a higher rate as required.
- Can be controlled either;
  - Manually boosted via multiple switches.
  - Automatically boosted, typically via humidity, CO<sub>2</sub> motion or other sensors.
- Normally sited remotely in a loft space or cupboard and ducted via rigid or semi rigid duct to outside air using the most economical route.
- Replacement air enters the building via background ventilators, typically in the form of window vents located in the head of window frames or walls. These should be fitted in each habitable room except wet rooms from which air is extracted.

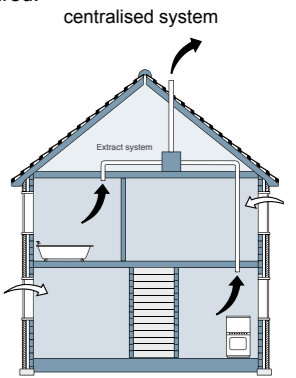

### SYSTEM 3.1 - De-centralised Continuous Mechanical Ventilation

Room	Continuous Extract Fan
Kitchen	13 l/sec
Utility Room	8 l/sec
Bathroom	8 l/sec
Toilet	6 l/sec

- Background vents in dry rooms only.
- Extracts continuously at a low rate and incorporates a boost facility to extract pollutants at a higher rate as required.
- Can be controlled either;
  - Manually boosted via multiple switches.
  - Automatically boosted, typically via humidity, CO<sub>2</sub> motion or other sensors.
- Normally sited remotely in a loft space or cupboard and ducted via rigid or semi rigid duct to outside air using the most economical route.
- Replacement air enters the building via background ventilators, typically in the form of window vents located in the head of window frames or walls. These should be fitted in each habitable room except wet rooms from which air is extracted.

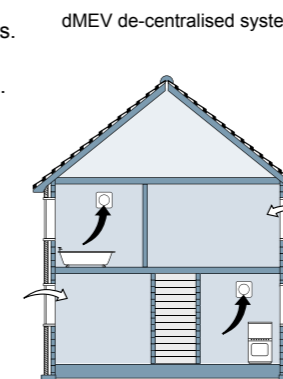

### SYSTEM 4 - Continuous Mechanical Supply and Extract with Heat Recovery

Room	Intermittent Extract Fan
Kitchen	Continuous Extract Rate
Utility Room	13 l/sec
Bathroom	8 l/sec
Toilet	6 l/sec

- Supplies & extracts air continuously at a low rate and incorporates a boost facility to extract pollutants and supply fresh outdoor air at a higher rate as required.
- Can be controlled either;
  - Manually boosted via multiple switches.
  - Automatically boosted, typically via humidity, CO<sub>2</sub> motion or other sensors.
- These should be clearly marked and located in an accessible location in or near the wet rooms.
- Normally sited in a cupboard or insulated loft and ducted via rigid duct to outside air.
- Replacement air is dealt with by balanced supply and extract.

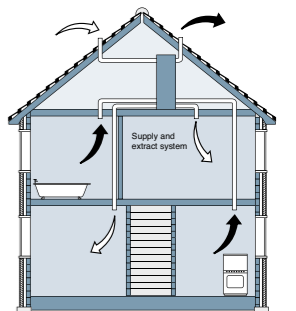

# RESIDENTIAL EXTRACTOR FANS

## SYSTEM 1 Background Ventilation and Intermittent Fans

### iCON®



- 3 size model range with a flow rate up to 75 l/s (270 m³/h)
- Available with Timer, Humidity Timer and Motion Sensor interchangeable controls
- Can be surface mounted or recessed
- Red Dot Design Award winning silent iris shutter prevents backdraughts
- A range of coloured covers available
- IPX4 rating
- SELV versions available
- 3 year warranty
- Meets building regulations flow rate requirements

### iCONsmart™

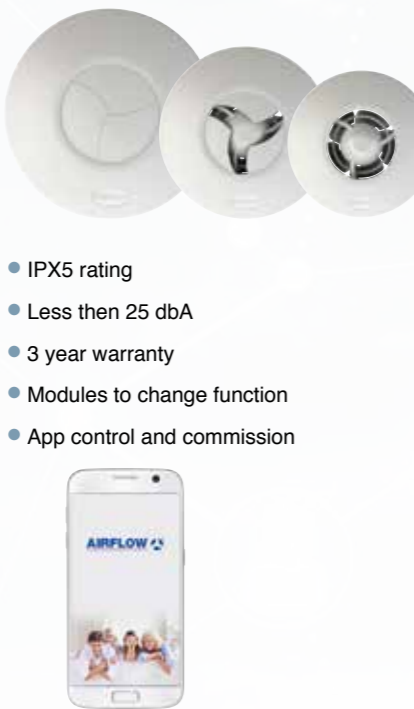

- IPX5 rating
- Less than 25 dbA
- 3 year warranty
- Modules to change function
- App control and commission

### TOP TIPS

- Three sizes in each model range provide the choice to ensure you do not need to under or over ventilate saving you energy.
- Use rigid ducting where possible. If you must use flexible ducting always pull taught to ensure a smooth airway.
- Loose ducting prevents best performance and collects dust and dirt. Consult the Domestic Ventilation Compliance guide for "Best Practice" installation advice.
- Ensure the doors meet regulations. Internal doors must allow for air to move underneath them.
- What goes out must first come in! Remember to open those trickle vents in the windows and walls to allow air into the dwelling and extract the damp, moist air from the bathroom / utility /kitchen. Without air coming in the fan cannot extract.

**Remember - To open trickle vents**



# RESIDENTIAL EXTRACTION SOLUTIONS

## SYSTEM 3 Centralised Continuous Mechanical Ventilation

### Airovent



- 2 unit range offering Whole House ventilation from a central location
- Flow rate up to 83-139 l/s (299-500 m³/h)
- All units use efficient Electrically Commutated (EC) motors
- Basic, Timer, Humidity controls
- Complies with Building Regulations and ErP
- 3 year warranty
- Airflex Pro compatible units available, utilise the 75 mm Airflex Pro with Airovent specific units

Versatile Mounting Position



Ceiling Mounted



Floor Mounted



Wall Mounted

### TOP TIPS

- Easy to install using 75 mm diameter Semi Rigid ducting to retro-fit your dwelling.
- New Builds with a high level of air tightness benefit by extracting a smaller amount of air continuously more often.
- Continuously running fans are virtually silent on trickle and use little energy.



Ideal solution for tenants where noise irritates. These solutions trickle at low speed in the background.

### QuietAir®



- 3 size model axial fan range with a flow rate up to 72 l/s (259 m³/h)
- Available with Timer, Humidity Timer, Motion Sensor and Continuous Ventilation controls
- Sound levels from only 25 dB(A)
- Very low SFP and power consumption
- Integral flow straightener makes it ideal for longer duct runs
- IPX5 Rating
- 3 year warranty
- Meets building regulations flow rate requirements

### Aventa in-Line



- Powerful 2 speed, in-line mixed flow fans
- Flow rate up to 88 l/s (280 m³/h)
- High pressure, low noise
- Basic and Timer versions available
- Available as a shower kit with LED
- Access to motor and impeller without dismantling ducting
- IPX4 Rating. Complies with Building Regulations and ErP
- 3 year warranty

SHOWER KIT AVAILABLE



### LOOVENT eco



- Centrifugal fan
- 2 speed filterless
- Smallest 30 l/s (110 m³/h) fan in its class
- Good for longer ducts
- Can be surface mounted or recessed in portrait or landscape
- Available with Timer, Humidity Timer and Motion Sensor controls
- Economical to operate - uses only 3.6 W
- IPX5 Rating.
- SELV versions available
- 5 year warranty

## SYSTEM 3.1 De-centralised Continuous Mechanical Ventilation

### LOOVENT eco dMEV



- Continuously running centrifugal fan
- 2 speed ventilation – flow rate up to 31 l/s (110 m³/h)
- Can be surface mounted or recessed in portrait or landscape
- Timer, Humidity Timer controls
- SELV versions available
- IPX5 Rating. Complies with Building Regulations, ErP and SAP eligible
- 5 year warranty

### iCONstant™



- Continuously running fan
- Quietest dMEV fan available – noise levels from 10dB(A)
- Flow rate up to 20 l/s (72 m³/h)
- Timer, Humidity Timer controls
- Guaranteed constant volume feature
- Only dMEV fan with IPX5 rating for walls and ceilings
- Complies with Building Regulations, ErP and SAP eligible
- 3 year warranty

### iCON dMEV



- Where there is a need for a continuous running fan at either 8 or 13 l/s but not all year round. When the fan is not in use the iris closes to prevent entry by insects or foreign bodies.

# MECHANICAL EXTRACT VENTILATION WITH HEAT RECOVERY (MVHR)

## Single unit solution

This type of ventilation is where the existing air in the property is extracted, as it is extracted the heat is removed (recovered). Then the unit uses this heat to warm up the new fresh air entering the property. So giving you consistent fresh air that is warmed up using the recovered heat.

### There are various solutions available:

Single room MVHR units, these are units that are installed in each room. They can be used in isolation in Wet rooms (ensuite, bathrooms, utility and kitchens) or can be used in habitable rooms (bedrooms, living rooms, dining rooms, home office).

Factors that need to be considered when using these units is the amount of background ventilation available and that they need to go on an external wall.

You can also use single units as a total house solution, this is done by pairing units up and is very useful for where retrofit does not easily allow for a central MVHR unit to be installed.

Central room MVHR units, these are for the whole house solution where they supply and extract air for the whole dwelling using one central unit. With central supply & extract you would need to use ducting

to reach each of the rooms.

Airflow have central solutions where units can utilise space that is not always optimised, above a hob in the kitchen is such an area, we have combined a MVHR unit and an extractor hood together. This unit is ideal for apartments where storage space is of a premium. Another such space is above the front door, we have units that can be placed above the front door and the filters accessed from outside, so no need to disturb the occupiers for any filter changes and maintenance.

## Wet room solution that meets regulations



### Unowet

- Ceramic heat recovery core
- Up to 88% heat recovery
- Ideal for use in wet rooms
- Meets building regulations for extraction System 1 or 3.1
- Works in recovery mode or extraction only
- Built in filter
- Built in humidity

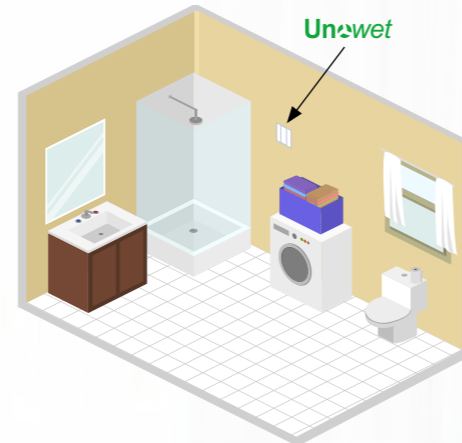

## Multi room extraction with Heat Recovery

### Habitable room solution, can also be combined to provide a total dwelling solution



### Unohab

- Lots of flexibility with low noise levels
- EC Motors and built in filter
- Can be connected to other units to provide total house solution
- Can be connected to extractor fans in wet rooms to ensure correct air volumes of air are supplied when fans need to extract air
- Systems can be designed to meet Part F System 1 or 3.1
- Used in retro fit or new build
- Used in Multiple Occupancy Properties
- Accessories that enable for the extract to be incorporated into properties with external wall insulation
- Suitable for various wall depths



# MVHR SINGLE DWELLING UNIT EXAMPLES

## 1 bed maisonette

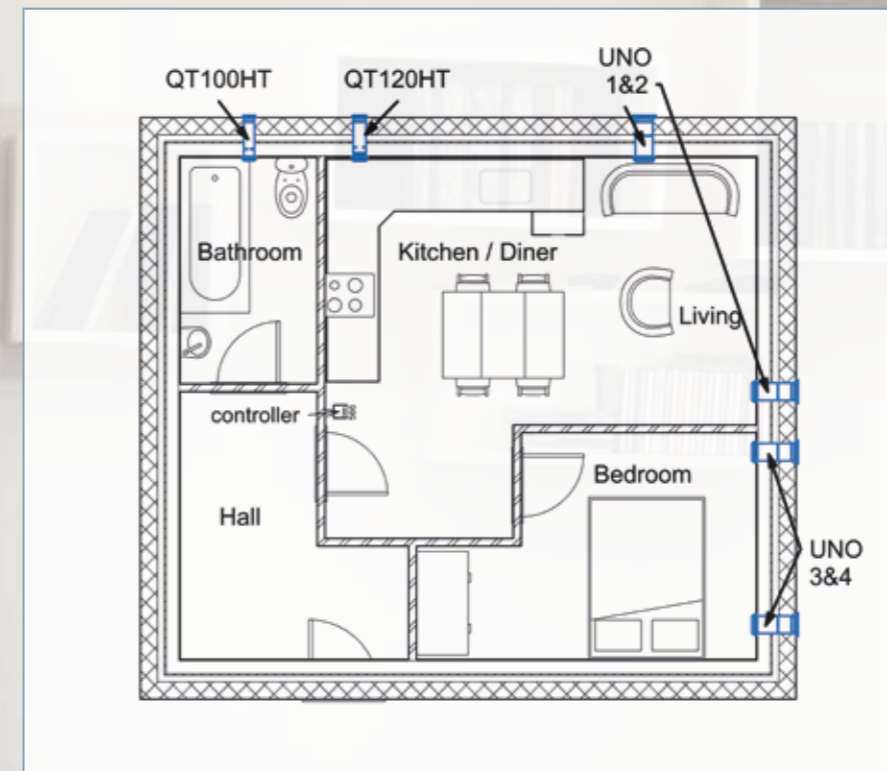

Two examples of where UNO has been used to provide an MVHR solution to a total dwelling.

They have been combined with QuietAir to provide a total system, so that the correct extraction rates are achieved to meet building regulations.

By using a control unit the UNOhab units communicate with the QuietAir extractor fans. When the QuietAir is activated in the wetrooms, the UNOhab switches to supply air only, ensuring there is enough replacement air entering the dwelling so the moist humid air can be removed.

### KEY

- UNO
- QuietAir

## 2 bed maisonette

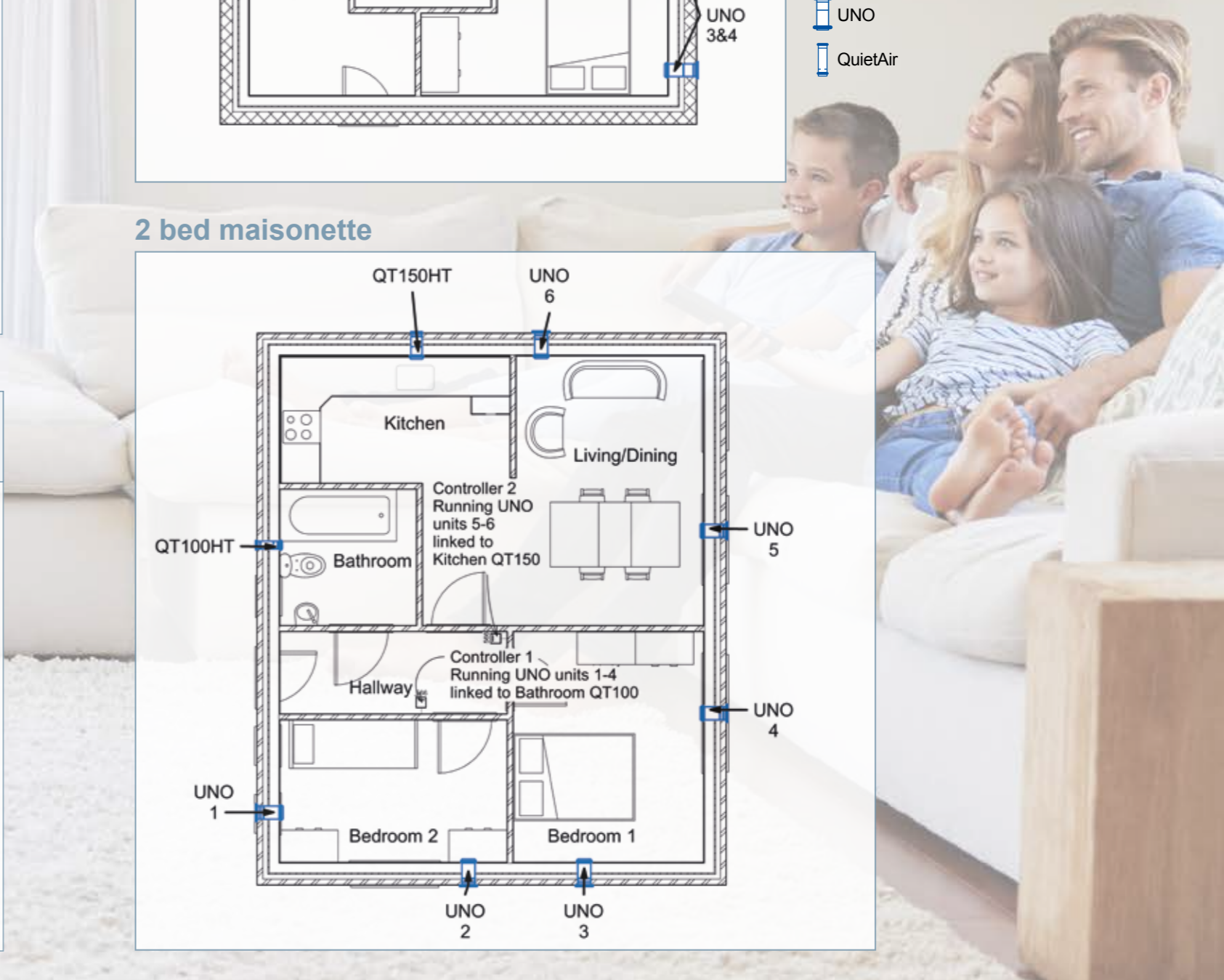
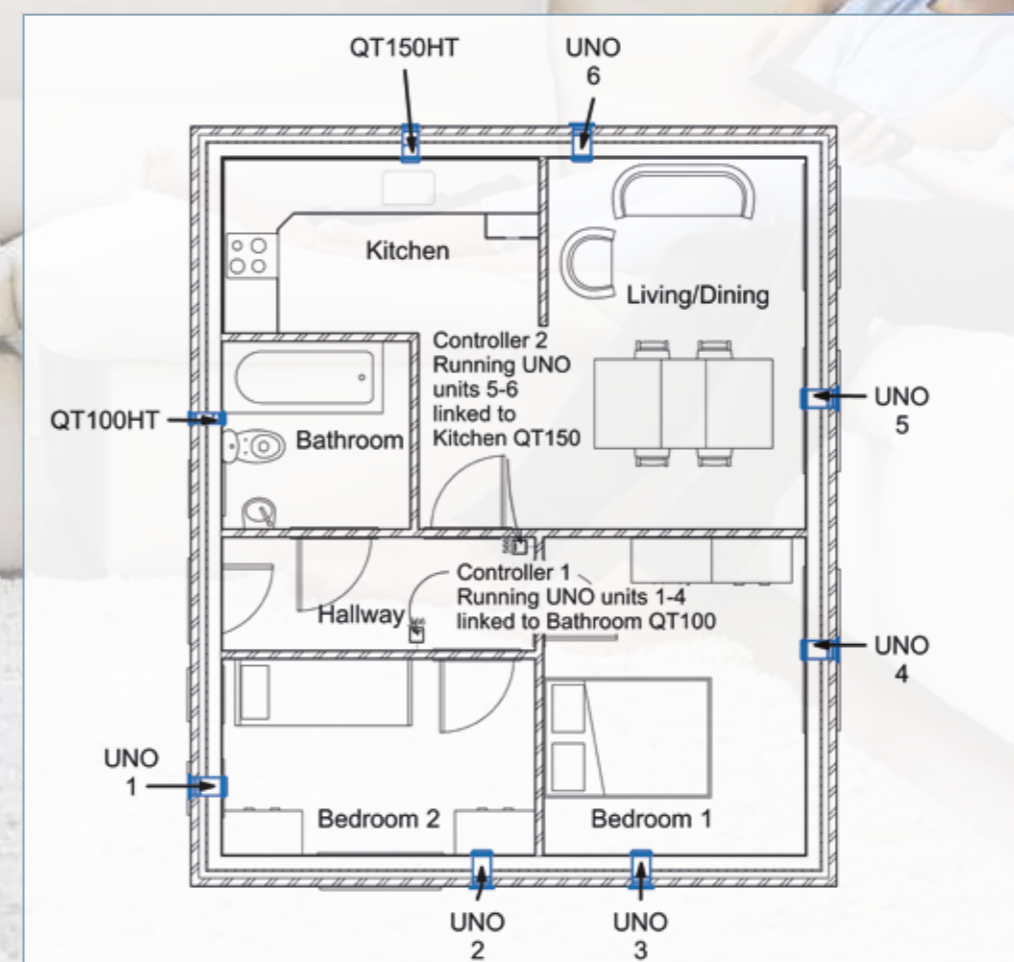

# INTERNET CONTROLLED SOLUTIONS

## Central unit solutions

### Adroit MVHR unit with built in extractor hood



**Adroit™**

- Internet control
- Integrated into kitchen units
- Located above the hob in the kitchen
- Recovers heat from the hob
- Extractor hood slim and stylish
- Full heat recovery for whole dwelling

# INTERNET CONTROLLED SOLUTIONS

### Entro - side entry

**Entro®**



- Suitable for dwellings up to 200 m<sup>2</sup>
- Flow rate up to 107 l/s
- Up to 93% thermal efficiency
- Can be fitted with 2 x G4 or 2 x F7 air filters
- Automatic, 100% summer bypass
- Floor, wall and ceiling mountable
- Complies with Building Regulations, ErP and SAP eligible
- Passive House approved when fitted with Part No 90000415
- 2 year warranty\*

### Adroit - top entry

**Adroit®**



- Range suitable for dwellings up to 400 m<sup>2</sup>
- Flow rate up to 258 l/s (929 m<sup>3</sup>/h) at 100 Pa
- Up to 93% thermal efficiency
- Remote "on the go" Internet and BMS control available
- Unique 2 x G4 and 1 x F7 air filter system
- Range available in left and right-hand models
- Complies with Building Regulations, ErP and Passive House Institute certified when fitted with integral electric heater
- 5 year warranty\*
- Accessories include CO<sub>2</sub> sensor, VOC Sensor, post heater
- No thermal bridging
- 20 mm insulation cased between powder coated casing panels
- 7 Adroit units to choose from
- Smart frost protection
- Remote access for fault diagnosis
- 7 day programmer
- Auto cut off switch when filters are changed

\*excludes motors. Motor warranty one year from date of purchase.

### Adroit Space Saver



**Adroit™**



- Internet control
- Can be positioned so that access for filter maintenance is from externally.
- Ceiling space inside front door is not often utilised
- Multiple spigot inlets and outlets to give full flexibility for installation
- 100% automatic by pass
- Triple filters

Easy access to replace filters

Heat Recovery

Removable, secure front cover panel for maintenance

Removable Heat Exchanger, for quick cleaning

Durable steel double skin casing with 20mm insulation



## Remove harmful incoming pollutants

### Inner city solutions - High efficiency NO<sub>x</sub> filters

Nitrogen Oxide (NO<sub>x</sub>) pollution, with other chemicals is linked to 40,000 premature UK deaths a year and is particularly prevalent in areas with heavy traffic such as industrial areas, busy roads and outside schools.

If you are living in a built-up area, it is important to ensure that you incorporate a NO<sub>x</sub> filtration system as part of your wider ventilation system.

Airflow's NO<sub>x</sub> filtration system works in conjunction with the unit's air filters to remove harmful air pollutants from the incoming air before it is distributed around the dwelling.

By ensuring that the incoming air is at healthy levels, you ensure that health and well-being of those inside is protected as well as improving persons concentration levels.

- Filters particulate matter and gases to remove pollutants prior to the air entering buildings
- Additional filtration system above the air filters within the MVHR unit
- Filters up to 90% of harmful NO<sub>x</sub> particles out the incoming air
- Improves the indoor air quality
- Variety of sizes available to fit your MVHR unit





# DUCTING SOLUTIONS

## Retro ducting system

This versatile and innovative ducting is designed around a coving system that can be incorporated within the visible part of the house or flat and is ideally suited to a standard footprint building design where there is a common entrance hallway with all the rooms branching off the hallway.

Retro ducting is lightweight, versatile and easy to fit making it the perfect choice for a discreet coving ducting application. This system can be used for System 4 (Mechanical Ventilation with Heat Recovery) in a supply and extract function and also System 3 (Mechanical Extract Ventilation) as an extract only duct system.

### Discreet coving air ducting ideal for renovations



- Discreet, quick to install air ducting for MVHR systems
- Designed for both new build and renovation projects
- Easy installation in 3 steps
- Coanda effect supply valves enable good circulation without the need for longer ducts
- Suitable for standard footprint building design
- Can be painted to suit inside décor of dwelling
- Negates the need for suspended ceiling to hide the ducting system
- Fire retardant to eu-b2 rating DIN 4102

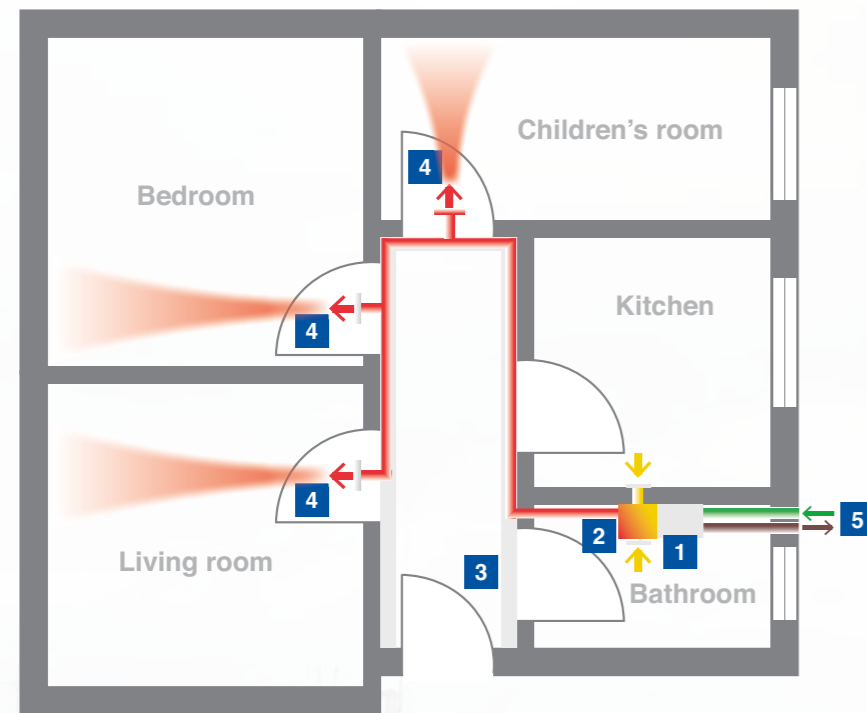

- = Supply Air to habitual rooms
- = Intake Air from outside
- = Extracted Air from wet rooms
- = Exhaust Air to outside

1. MVHR unit
2. Distribution box
3. Retro ducting
4. Coanda valves above door
5. Intake and extract

So easy to fit



Step 1



Step 2



Step 3

# DUCTING SOLUTIONS

## Coanda Air Valve - Works well with Retro ducting

When coanda valves are used with Airflex Retro, it removes the need for the valves to be located in the corner of the room. Therefore making installation that much easier.

Coanda valves supply air into a habitable room more effectively than conventional air valves. By directing a low pressure jet of air from a high level valve the air flow attaches itself to the ceiling and remains attached for a longer distance, thereby increasing the "throw" of the valve.

Using Coanda valves enable a greater more even distribution of air throughout the room having more positive effect on the internal atmosphere.

Coanda Valves can also be used as conventional extract valves for whole house balanced ventilation systems.

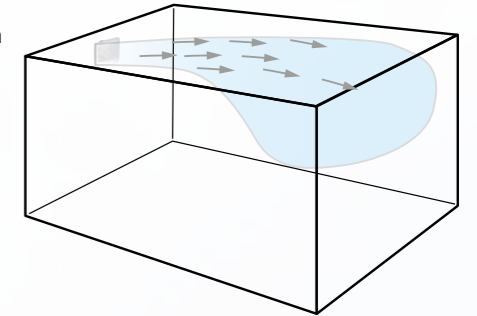
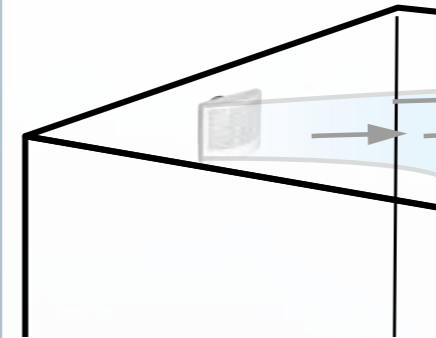

## AIRFLEX PRO

### Semi rigid ducting

A quick and easy to fit system of semi-rigid ducting that can result in up to 70% time saving during the on-site installation process, compared to rigid or spiral duct methods.

This innovative system uses low resistance and antibacterial smooth round and oval tubes which connect each room to the heat recovery or ventilation unit via an air distribution box.

The Airflex Pro Oval ducting is designed to equal the hydraulic performance of Airflex Pro Round so both types can be used within the same system without a loss of performance.

Semi rigid ducting without joints. Performance data is now recognised by the U.K. Government as an input for Standard Assessment Procedure (SAP) calculations via SAP eligible.

### Mix and Match, "Oval or Round" = No Loss of Performance



- Zero leakage ensures highest performance
- Fire rated to EN13501-1 Class E
- 70% time saving on installation
- Interchangeable ducting system (75 mm round / 51 mm x 114 mm oval) without any hydraulic pressure loss
- Compact, suits narrow joists and low ceiling voids
- Durable with high crushability (13 kN/m<sup>2</sup>)
- Smooth bore with antistatic and antibacterial lining
- Easy to clean when installed
- SAP eligible ducting (non-jointed)

#### Airflex Pro Round



#### Airflex Pro Oval



# Loovent eco

## The Powerful Performer

**5**  
YEAR  
Warranty

The 4th generation of the Million Plus selling Loovent extractor fan. With a pedigree of proven reliability and outstanding performance it really is a fan for all applications.

### Many options – A Fan for all reasons

<b>Intermittent</b> Loovent eco T 	<b>Intermittent SELV</b> Loovent eco SELV 	<b>Continuous dMEV</b> Loovent eco dMEV T 	<b>Continuous SELV dMEV</b> Loovent eco SELV dMEV T 
<b>Loovent eco HT</b> 	<b>Loovent eco SELV HT</b> 	<b>Loovent eco dMEV HT</b> 	<b>Loovent eco SELV dMEV HT</b> 
<b>Loovent eco MST</b> 			



### Why Choose Loovent eco?

#### Experience makes the difference

- Two speed - intermittent & continuous models
- Longer lengths of ducting no problem. Delivers 15 l/s through 6m of flexible duct
- Sound pressure levels as low as 25 dB(A) at normal operation
- For New Build and Social Housing upgrades
- Energy efficient DC motor, from just 2.8 W standard
- Surface or recessed, portrait or landscape, wall or cavity
- IPX5 rating for both wall and ceiling install
- The smallest footprint in its class
- Quick and easy to install, proven over four decades
- Fast to fit and interchangeable with older versions of Loovent 01C and 01 Fans, same mounting holes and outlet position
- At least 40,000 hours constant operation
- No noise magnetic anti-backdraught flap
- Anti-strangle pull cord, electrical cut out when cover removed
- Made of 100% recyclable materials
- Complies with latest Building Regulations requirements
- 5 year warranty

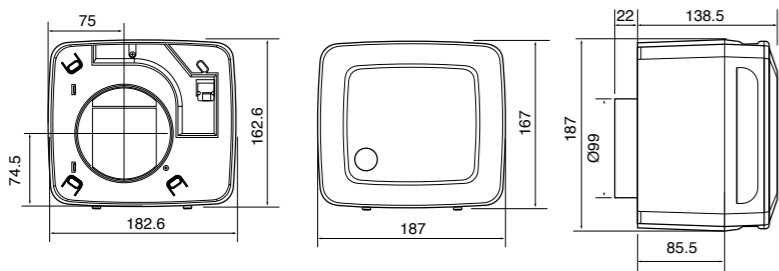

### Suitable for New Build and an easy upgrade from old Loovents



Bezel available for neat finish



## NOT ALL SYSTEMS ARE AS EFFECTIVE

### Considering Positive Input Ventilation (PIV)?

A system originally developed in the 1970's for leaky Victorian houses continues to be chosen as a "Quick Fix" for some Social Housing upgrades.

However, as new homes are built to a better standard and renovations include significant insulation, there are few factors to be considered.

### Perception can be misleading

The actual drawbacks of PIV are that the air displacement principle can only work on leaky buildings as there is little control over where the air goes.

Not as suitable for well insulated new build properties where there are definitely fewer

leakage paths.

Poorly insulated ceilings allow humid air to rise into the loft space, which means the damp air is re-circulated again.

Much loft space air is not "fresh" as it is subject to other airborne construction material contaminants.

Difficult access to filter for routine cleaning / replacement. In tenant properties they will never do it, so is there a landlord replacement schedule?

To avoid frost damage to the unit and to warm up in cold air in an uninsulated loft space in winter, a costly (24 / 7) electric heater is used warm up incoming cold air.

If a heater is not used, cool air (i.e. a draught) is forced into the hallway / stairs

dropping the temperature in those areas.

Noisy. The joist mounted fan is a short distance from the ceiling input diffuser. Transfer grilles may be needed in doors to rooms which do not open directly on to the hallway.

Older properties won't have been built with a 10mm gap undercut to internal doors. Consequently air circulation, condensation, dampness and mould issues are not addressed in these rooms.

Possible noise / vibration issues from units screwed to ceiling joists. Unit runs continually so creating a constant sound.

Is the loft space really a source of ventilation air you want to use? Relying on an air filter to condition contaminated air seems dubious.

### More critically

PIV forces damp, moist air into the fabric of the building through the wall sockets, into wooden windows, through vents and gaps in the floor boards, contaminating plaster and insulation materials with humid air.

When an occupant opens a window they will create a path of least resistance nullifying the positive pressure in the dwelling which the device is designed to maintain and thereby creating a condition where the damp, moist air in the wet rooms will not be removed.

### Does it work?

PIV is not recognised as one of the four primary approved ventilation systems by the Building Regulations, Approved Document F1, 2010 (amended 2013) Means of Ventilation. In fact this methodology was removed from the Building Regulations Approved Document F list of approved systems in 2006 because of doubts about its effectiveness and performance issues.

- Introduces loft air into the dwelling.
- Positively pressurises the inside of the dwelling to create air or circulation by forcing damp air to escape through existing gaps, vents, floorboards, windows and cracks.
- Condensation is supposedly eliminated as the damp, moist indoor environment is reduced with filtered (but hardly fresh) air from the loft.

### How do you test the efficiency of a PIV installation?

- The Building Regulations require that 'notifiable work' ie: repairs, maintenance and upgrades/improvement that require planning permission require sign off by Building Control. Similar to new build installations, prescribed ventilation rates as documented in Building Regulations Approved Document F and are required to be measured, recorded and submitted to the local authority Building Control.

- But how do you measure the effective circulation of a device which blows air into a leaky dwelling? Without a whole house leakage test who knows how much the dwelling is leaking?
- Approved extract systems 1,2,3 and 4 can be accurately measured with a Powered Flow Hood to determine air flow rates. Drawing air from a loft space and pumping it into a dwelling which may not have open path ways (ie: undercuts to doors) to the wet rooms and then relying on the moist air to leach out of cracks or vents in the dwelling is much more difficult and adds a huge element of uncertainty.





# VENTILATION MATTERS

Protect the health of your tenants  
and the fabric of your property

Ineffective ventilation can lead to mould and condensation, resulting in poor air quality that affects people's health and damp conditions that threaten the value of your investment. The good news is that the solution's a simple one. We are experts in ventilation systems and have high-quality, low maintenance products for all types of rental and social housing.

To choose your ventilation system visit [www.airflowselectair.co.uk](http://www.airflowselectair.co.uk) or call **01494 560800**

[www.airflow.com](http://www.airflow.com)

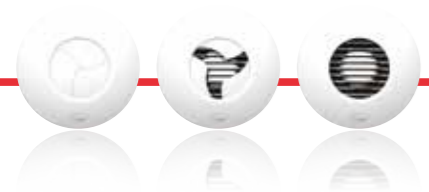

A BREATH OF FRESH AIR

**MY HEALTH** **MY HOME**

Explore the house to discover what could be making you ill...

**Mould in the bathroom**  
Mould releases spores and fungal metabolites which are exacerbating agents of respiratory problems, allergic rhinitis and asthma.

Volatle organic compounds (VOCs) can irritate the lungs. Acetaldehyde and benzene, two VOCs washing gives off, are carcinogens. Most of the VOCs can't be traced to any particular ingredient in the detergent.

**drying washing inside**

**wood burning fireplaces**  
Particle pollution in smoke can damage lung tissue and lead to serious respiratory problems when breathed in high concentrations.

**carpets**  
Carpets harbour dirt, dust mites, pet hair, fungus and other potentially harmful particles that can aggravate the lungs, trigger asthma attacks or send some people into allergic fits.

**cooking with gas**  
Cooking on a gas hob gives off nitrogen dioxide, acrolein, formaldehyde and carbon monoxide. These have been linked to respiratory symptoms and cancer.

**paints**  
Paints release volatile organic compounds that may have a range of subtle health effects if breathed in over a long period of time.

## EXPERT ADVICE

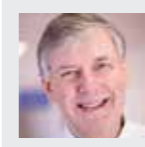

**Peter Howarth, Professor of Allergy and Respiratory medicine at Southampton University, calls for increased awareness of what is being termed 'Toxic Home Syndrome'.**

"Toxic Home Syndrome occurs when individuals and families are exposed to a potent mix of airborne pollutants within the home arising from poor ventilation, causing respiratory and skin diseases to occur more frequently.

I have had many patients come to me with serious respiratory conditions due to pollutants within the home. With respect to asthma, mould allergy is recognised to be associated with worse asthma and poorer asthma control. The presence of moulds within the home is a reflection of poor ventilation and increased humidity. Homes with mould are also likely to have higher house dust mite allergen levels and this may worsen both respiratory and skin conditions. The lack of adequate ventilation within the home can also be associated with the build up of non-allergenic noxious fumes which are detrimental to health."



### THE EFFECTS OF POOR VENTILATION

- Nearly 90% of asthma sufferers are allergic to allergy DER P1 which is present in House Dust Mite droppings
  - HDM require high humidity - typically over 70% to live and reproduce
- It is clear that lowering humidity levels will help to keep HDM colonies in-check and thereby reduce the incidence of asthma attacks

## WHY DO WE NEED VENTILATION?

Ventilation is required for...

- Provision of fresh air for breathing
- Dilution and / or removal of airborne pollutants and odours
- Controlling excess humidity arising from water vapour in the indoor air
- Provision of air required by fuel burning appliances

## MOISTURE PRODUCTION?

A family of 4 produces up to 14 litres (24 pints) of moisture per day:

- Bathing & Showering
- Washing & Drying
- Cooking
- Breathing

## Fan selection software

### SELECTAIR

[airflowselectair.co.uk](http://airflowselectair.co.uk)

Airflow Selectair selection software allows the user to select products from our Domestic, Commercial and Industrial fan ranges and also select from our Heat Recovery range suitable for their

application. The software is hosted within the Airflow website.

Selectair software has been designed to ensure that products are

selected to fulfill the requirements of your application. By following a logical and easy to use sequence fans are listed which are suitable for the room of your choice, through the wall or ducted installation and the type of ducting you will be using.

By automatically calculating the pressure drop values for your requirement, a choice of products are linked to ensure "installed performance" criteria is met. This gives the specifier the confidence to know that choosing a fan from the products offered will deliver the performance expected to meet the latest building regulations for fast, effective ventilation.



## Field support



Airflow do not view our customers just as a short term arrangement. We believe that by working together in partnership we can achieve better results in realising our shared objectives to deliver efficient, effective and reliable ventilation solutions so that you and your tenants are living in a healthy environment.

Our knowledgeable, trained technicians can provide support to ensure your ventilation projects run smoothly and where issues arise they can advise on the most suitable course of action to provide a successful outcome.

Airflow offers full field support across the UK, our after sales team can deal with any post sale needs and requirements. For any pre sale needs and requirements then our technical sales team can assist.



## Technical



We have a fully trained technical team in our UK head office and in the field, that can provide assistance and application advice on all ventilation matters. From choosing a residential extract fan to specifying a commercial MVHR system.

## System design

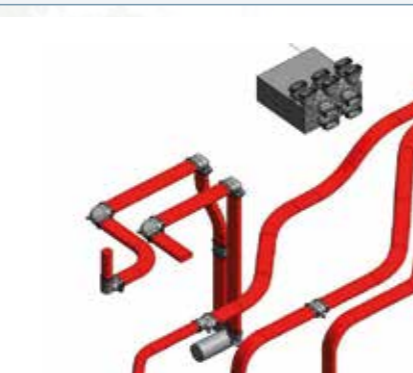

If you are considering specifying a ventilation system why not send us your drawings. We can advise on the most suitable product complete with compatible accessories to ensure an effective installation.

Send your drawings to: [plans@airflow.com](mailto:plans@airflow.com)

## BIM

We also have product data in industry leading format for those designers using BIM software, so that all information is available in one file.

Airflow's BIM models adhere to criteria required by the following BIM standards: IFC, COBie, RIBA, CIBSE

Airflow also provides you with bespoke information not covered by these standards, such as ErP data and whether a product is Passivhaus approved.

Airflow's BIM models are compatible with Revit 2015 and newer. The models are available Revit 2015 as standard and will automatically upgrade to the user's version of Revit upon first use.

[airflow.com/BIM](http://airflow.com/BIM)

## Contact us



**Airflow Developments Limited**  
Tel: 01494 525252  
e-mail: [info@airflow.com](mailto:info@airflow.com)

**Customer Services**  
Tel: 01494 560800  
e-mail: [customer\\_services@airflow.com](mailto:customer_services@airflow.com)

**Technical Support**  
Tel: 01494 560950  
e-mail: [technical\\_sales@airflow.com](mailto:technical_sales@airflow.com)

**Sales**  
Tel: 01494 560800  
e-mail: [sales@airflow.com](mailto:sales@airflow.com)

**Airflow Developments Limited**  
Aidelle House, Lancaster Road,  
Cressex Business Park,  
High Wycombe, Buckinghamshire,  
United Kingdom, HP12 3QP  
Registered company 550374  
[airflow.com](http://airflow.com)



## Product available from any of our resellers, some listed below

- BSS
- Buildbase
- CEF
- City plumbing supplies
- Denmans
- Edmundson
- Electric Center
- Electricbase
- Eyre & Elliston
- Gibbs and Dandy
- Grahams
- Holland House
- Jewson
- PTS
- Rexel
- TLC
- Travis Perkins
- Yesss Electrical
- Members of the following buying groups Fegime and IBA
- Many other independent electrical wholesalers



**UNITED KINGDOM (head office)**

**Airflow Developments Limited**  
Aidelle House, Lancaster Road  
Cressex Business Park  
High Wycombe, Bucks. HP12 3QP.

Tel: +44 (0) 1494 525252  
Email: [info@airflow.com](mailto:info@airflow.com)  
Web: [airflow.com](http://airflow.com)

**GERMANY**

**Airflow Lufttechnik GmbH**  
Postfach 1208  
D-53349  
Rheinbach, Germany

Tel: +49 (0) 2226 92050  
Email: [info@airflow.de](mailto:info@airflow.de)  
Web: [airflow.de](http://airflow.de)

**CZECH REPUBLIC**

**Airflow Lufttechnik - Praha**  
Hostynska 520  
10800 Praha 10  
Prague, Czech Republic

Tel: +42 (0) 2747 72230  
Email: [info@airflow.cz](mailto:info@airflow.cz)  
Web: [airflow.cz](http://airflow.cz)